

◀ PNC ACTUATOR

**REAL INNOVATION  
REAL PERFORMANCE**

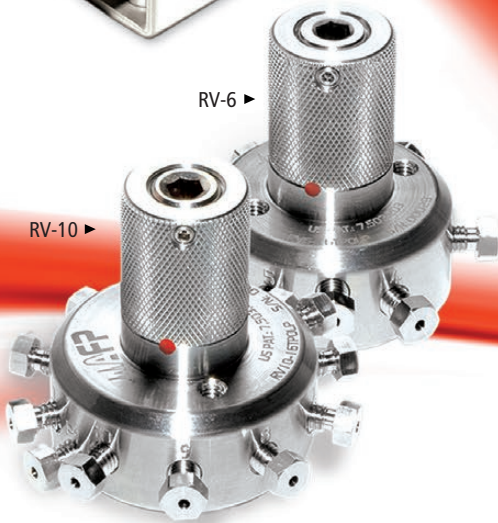

RV-6 ▶

RV-10 ▶

EAC ACTUATOR ▶



## RV-SERIES CONICAL ROTARY GC VALVE \*

### Common features:

- Can be mounted on existing automated drives. This allows for direct replacement with better performance. Adding the new purge concept and the many mechanical issues that have been improved, it results in outstanding performances. For more information about this, please see the Design Report 2.
- New set of performances, thanks to our unique features. Thanks to unique new concepts.

Since the early days of analytical instruments, rotary valves have been around. The same concept has been in use over 60 years. Until recently, to manipulate various samples, the most sensitive instrument technology was still relying on valve concepts introduced many decades ago. Existing rotary valves are plagued with lifetime limitation and increasing leak rate, over the time.

Here are presented our innovative concepts in rotary valve for analytical instrumentation.

The unique purge concept extends valve's lifetime by the cleaning/washing action, eliminates or deviate leak by the dynamic purging action. Special surface treatments, unique stator design and the purge system lead to a level of performance unachieved before.

Our new line of rotary GC valves is divided in two categories. First, there is a version with a purging / sealing groove, to protect against inboard / outboard contamination. The second one still has the benefit of inboard / outboard purging / sealing groove but also has such grooves between the process grooves in the rotor. This helps to eliminate the interference caused by cross port leaks. In all versions, the rotary valves are available in 4, 6 and 10 ports. We also offer the option to have the valve with internal sampling loop. There are different volume size available, 0.05  $\mu$ l, 0.2  $\mu$ l, 0.5  $\mu$ l, 1.0  $\mu$ l and 2.0  $\mu$ l. Finally, there is the sample stream selection version, with a purge channel surrounding each inlet port, to eliminate cross port leaks.

\* U.S.pat# 7,503,203 / Chinese pat# CN101044346 / other patents pending.

# ROTOR CONFIGURATION

## “PROPRIETARY SURFACE TREATMENT”

When rotor manufacturing step is finish, extra surface treatment is done and the rotor is match into a stator. The assembly is tune and seal. This treatment create an inert lubrication thin film. A high temperature rotor typically made of Vespel could be use at low and high temperature. No need for rotor replacement for this. Rotor doesn't need to be replace for the lifetime of the valve, when operate as per specification.

### THE “OLP” SERIES

In this configuration, the rotor has a built-in protection against inboard and outboard contamination. It allows a longer working period in variable temperature conditions. Furthermore, when it's working with high sensitivity detectors with a low molecular weight gas such as helium as the carrier gas, this purging/ sealing groove is normally swept with the carrier gas. The purging gas pressure and flow are normally adjusted to compensate for long term wear. It eliminate atmosphere contamination of carrier gas and fugitive emission from the sample. No need for separate purge enclosure.

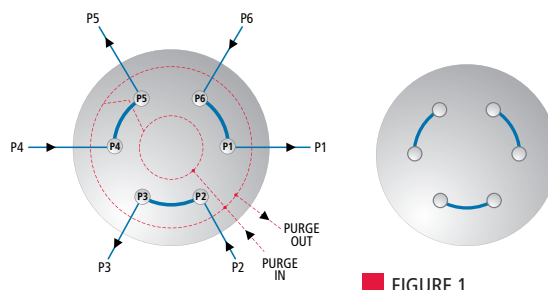

FIGURE 1



FIGURE 2

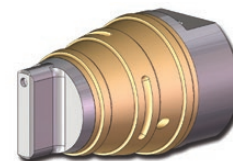

FIGURE 3

### THE “CLP” SERIES

Same features and benefits of “OLP” purge type with more.

### The “CLP” SERIES

The “OLP” type rotor design succeeds in eliminating inboard/outboard contamination. However we modified it to address the cross-port leak problem, which will eventually happen during a rotary valve lifetime. Although we succeeded in reducing friction between rotor and stator, there would still be some wear. This is why we designed the “CLP” type rotor. This will make a big difference. The “CLP” type rotor is available in two versions, i.e. “CLP-D” and “CLP-S”.

### The “CLP-D” SERIES: DYNAMIC PURGING

This type of rotor, shown in figure 9-A, is the “CLP-D” type. The “D” stands for dynamic. This means that there is a continuous purge flow at all time into the system. The “CLP” type rotor is simply an “OLP” type with extra purging grooves between the process grooves as shown in figure 7-A. So, each process groove is isolated by a purge groove.

Any leak developing over time between any of the process grooves will simply be carried away by these radial purge grooves. It also allows on line diagnostic testing of the valve by monitoring the quality of the purge gas coming from the valve. This is an interesting feature for critical application. The use of our DV-3 series valve allows an easy integration for such configuration. There is another bonus with these grooves each time the valve is actuated, these purge grooves clean the stator surface evacuating dust particles that could build-up over time.

These extra grooves will, in fact, extend the lifetime of the valve. In an HPLC application, one could use a solvent to provide a washing action on the stator, to decrease the carryover effect and particle built-up.

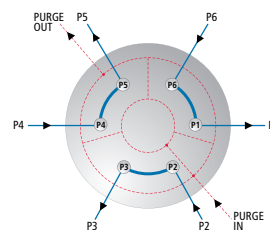

FIGURE 7-A (CLP-D)

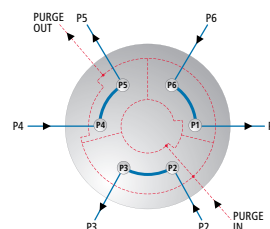

FIGURE 7-B (CLP-S)

These purging grooves are done axially in the rotor. Please see figure 9-A. They are machined at a special angle relative to each other. This is done to make sure that there will be only one purging groove, that will cross a stator's port at a time. This means that when the valve is actuated there will be a little bit of carrier that will suddenly flow into the purge. In the same manner there will also be a part of the sample fluid that will flow into the purge. However there will be NO mixing since there is only one port in contact with the purge grooves at a time. Since the valve rotation time is relatively short, this has very little impact, if any, on most gaseous applications.

## The "CLP-S" SERIES: STATIC PURGING

The main difference between the "S" version and the "D" is that in the "S" version, the purge flow is interrupted when the valve is actuated. The rotor is designed in a way, that when it rotates, the inlet and outlet purge ports are closed. The purge flow is allowed only when the valve is in its final position. Please see figure 7-B and 9-B. The "S" stands for static. This way when the purging grooves cross one port, there will be no flow from that port through the purge vent. It makes sense when samples are pressurized liquids. Some other applications can also benefit of this feature.



FIGURE 8

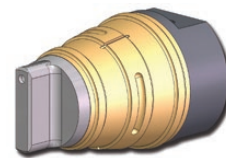

FIGURE 9-A

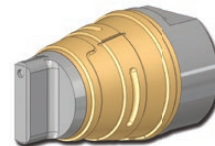

FIGURE 9-B

## THE "S" SERIES

This series is a sample stream selection rotary valve. The rotor has a built in protection against inboard and outboard contamination. There are also extra grooves to allow the isolation between various selections. It allows a longer working period in variable temperature conditions. Furthermore, when the rotary valve is working with high sensitivity detectors with low molecular weight gas such as helium as the carrier gas this purging/sealing groove is normally swept with the carrier gas. The purging gas pressure and flow are normally adjusted to compensate for long term wear.

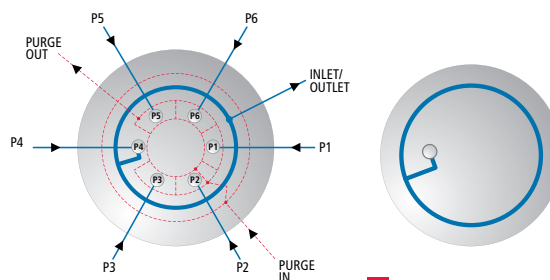

FIGURE 4



FIGURE 5

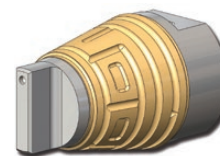
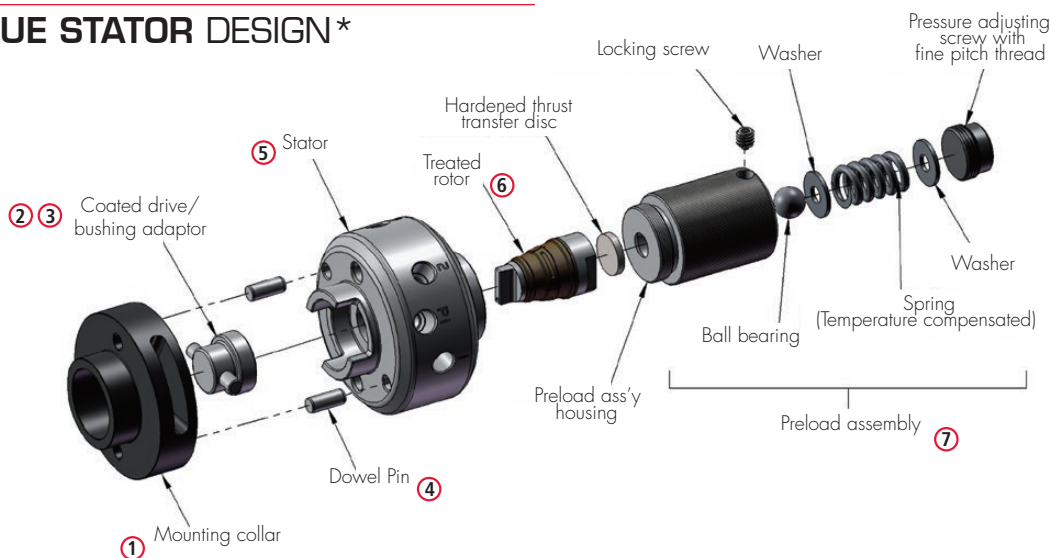

FIGURE 6

## UNIQUE STATOR DESIGN\*



- ① Mounting collar design for anti-rotation assembly.
- ② Extended pin design drive adaptor.
- ③ Coated drive/bushing that minimize side loading effect.
- ④ Anti-rotation dowel pins.

\* Patent Pending

- ⑤ Purge stator.
- ⑥ Treated Rotor. No-sticking action.
- ⑦ - Preload assembly build with a locking screw and fine pitch thread for precise pressure adjusting.  
- Temperature compensated spring.

## RV ROTOR MATERIAL SELECTION GUIDELINE

### AFPR-1: Modified PTFE\*

- Max T°: 200°C
- **Typical Use:** Due to its superior resistance to most chemicals, PTFE is mainly used in applications with aggressive media. It is attacked only by molten alkali metals and by fluorine at high temperatures. Being self-lubricating, it can be a good choice in many applications. However, pressure and temperature limitation can be restrictive. Depending on process pressure and media, the maximum temperature can reach 200°C. PTFE is fairly porous, so permeability, diffusion and absorption problems may arise with its use.

### AFPR-2: Modified PEEK\*

- Max T°: 225°C
- **Typical Use:** Our standard material, PEEK is biocompatible and relatively inert. It's compatible with most of the common solvents, so it can be used in the majority of HPLC-GC applications. Although PEEK tolerates the whole pH range, strong oxidizing media, like sulphuric and nitric acids, they must be avoided.

### AFPR-3: Modified Polyimide\*

- Max T°: 260°C (350°C short exposures)
- **Typical Use:** Preferred for high temperature applications, Polyimide offers good wear and chemical resistances. Steam, ammonia, strong oxidizers and media with pH of 10 or more, all are not compatible with Polyimide.

### AFPR-4: Modified PPS\*

- Max T°: 175°C
- **Typical Use:** Recommended for gasoline\*. Pretty inert to all solvents, acids and bases, PPS should be used in applications where PEEK doesn't fair well. However, PPS has more restrictions to temperature than PEEK.

\* Note: To be used with treated stator for best performance.

### AFPR-X: Custom Material\*

- Many other materials have been done as requested by specific OEM customers. Please contact us with your specific needs.

\*The modified material means that a special processing and treatment have been done by AFP to modify the surface activity of the raw material selected. This result in a better tribological related performance.

Note: One size fit all material does not exist. Users must select proper stator and rotor material to make sure the target application will be done in a safe manner. Please contact us if you are not sure which material to use for your application.

	Gasoline	Strong Acids	Strong Bases	Hydrocarbons	Oxidizing Agents	Alcohols	Ketones	Esters	Steam	Max. Continuous Temperature
AFP® PTFE	E	E	E	E	E	E	E	E	E	200°C
AFP® PEEK	E	F	E	E	F	E	E	E	E	225°C
AFP® Polyimide	F	F	N	G	N	E	G	E	N	260°C*
AFP® PPS	E	G	E	E	G	E	E	E	G	175°C

E : Excellent

G : Good

F : Fair

N : Not Recommended

\*350°C short exposure

## CLEANING PROCEDURE

Please refer to our web site for AFPC-2 i.e. AFP cleaning procedure for O2 compatibility.

## LEAK TESTING

Leak rates are verified at maximum operation conditions. Please see engineering note EN-01, on our website, for more information. Verified on a VARIAN™ helium leak mass spectrometer detector and on AFP® proprietary online leak detection system.

## RV-SERIES CONFIGURATION

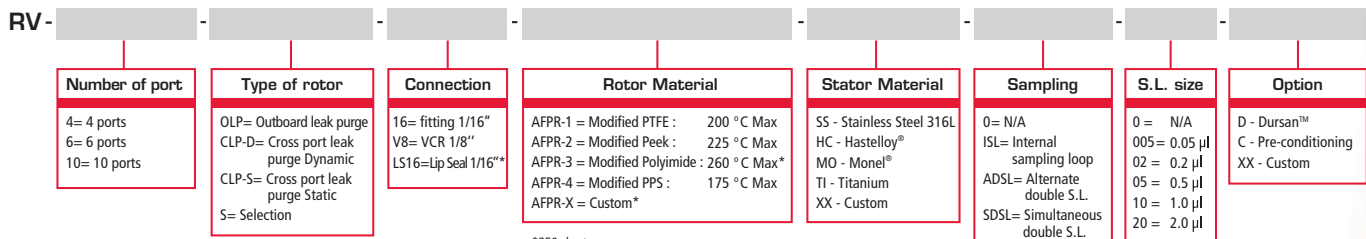

\*350 short exposure

\*Custom Rotor material : Many other material have been done as requested by specific O.E.M.S. customer. Please contact us with your specific needs.

Please refer to rotor material selection guideline

### Option

- D** = Dursan™ is a coating designed to improve the inertness, hardness, and corrosion resistance of stainless steel. It is ideal for sulfur, H2S, mercaptan, ammonia and mercury sampling.
- C** = Pre-conditioning; this allows the elimination of atmospheric contaminants from the wetted internal surface.
- XX** = Custom request.

**\*Lip Seal:** Lip Seal fitting is our new patent pending AFP fitting detail. This reduces the dead volume, eliminates the rotation of the ferrule and improves the sealing resulting in an improved connection for valve and fitting. This is very beneficial for any analytical high sensitivity instrumentation. Sealing integrity of a VCR fitting with the flexibility of a compression fitting. Please refer to Design Report 3 (DR-3) in the Analytical Flow Product Cookbook.

\*Patent Pending

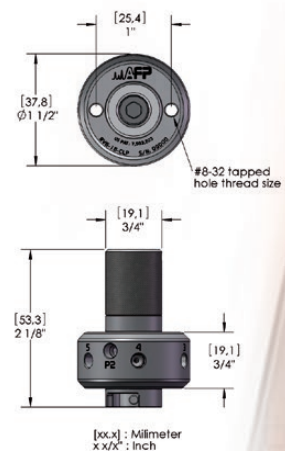

## REPLACEMENT ROTOR

ROT - [ ] - [ ] - [ ] - [ ] - [ ]

Number of ports	Type of rotor	Rotor Material	Sampling	S.L. size
4= 4 ports 6= 6 ports 10= 10 ports	OLP= Outboard leak purge CLP-D= Cross-port leak purge Dynamic CLP-S= Cross-port leak purge Static S= Selection	AFPR-1 = Modified PTFE : 200 °C Max AFPR-2 = Modified Peek : 225 °C Max AFPR-3 = Modified Polyimide : 260 °C Max* AFPR-4 = Modified PPS : 175 °C Max* AFPR-X = Custom*	0= N/A ISL= Internal sampling loop ADSL= Alternate double S.L. SDSL= Simultaneous double S.L.	0 = N/A 005 = 0.05 µl 02 = 0.2 µl 05 = 0.5 µl 10 = 1.0 µl 20 = 2.0 µl

\*350 °C short exposure  
\*Custom Rotor material : Many other material have been done as requested by specific O.E.M.S. customer. Please contact us with your specific needs.

Please refer to rotor material selection guideline

## ACCESSORIES

These actuators are by far the best way to actuate a conical rotary valve. Only rotational force is transmitted to the rotor, no radial force, no side-loading.

### PNEUMATIC ACTUATOR

- Long lifetime, 5 million cycles.
- Standard version work up to 200°C.  
\*Eliminates the needs of standoff normally used with valve heated boxes and ovens.
- Adjustable stroke, eliminates valve overloading.
- Optional miniature proximity sensors.  
\*Used for realtime position feedback.
- Supports competitor's valve.
- Extremely long lifetime when used with AFP® valve.
- Various mounting brackets and standoffs are available.

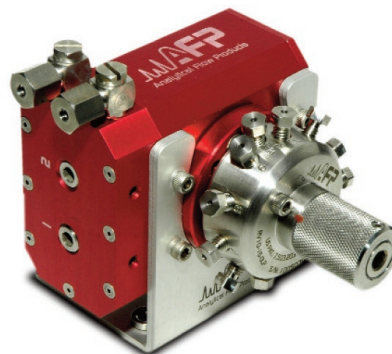

See PNC actuator brochure for more details

### ELECTRICAL ACTUATOR

- In a one box design.
- Programmable.
- Used for two or multiposition rotary valve.
- Eliminates side loading on rotor seal.
- Only rotational force transmitted to the rotor, when used with AFP® valve.
- Supports competitor's valve.
- Various control supported :
  - \* Serial communication
  - \* Individual digital input
  - \* BCD digital input



See MEA actuator brochure for more details

## OFFERING COMPARISON OF GC ROTARY VALVES

FEATURES AND BENEFITS	AFP®	COMPETITOR
<b>Unique Purge Design Concept / Unique Benefits</b> Allows safe operation with hazardous gases Allows real time monitoring of the health of the valve Eliminates fugitive emission and inboard/outboard contamination Eliminates cross port leak (CLP type)	A • • • A	N/A N/A N/A N/A N/A
<b>Valve Port Configuration</b> 1/16" ports, Lip Seal 1/16", Lip Seal 1/8" 1/32" ports / 1/8 VCR Welded tube connection	• A A	• N/A N/A
<b>Valve's Stator Design</b> No Rotor Side-loading { Bushing guided Double stopper design Anti-rotation dowel pin Pre-load assembly lock screw Pre-load assembly fine pitch thread adjustment screw Constant force related to temperature spring material	• • • • • •	N/A N/A N/A N/A N/A N/A
<b>Valve's Rotor Design</b> Surface treatment that allow same material to be used at low an high temperature	•	N/A
<b>Actuation</b> Support the feature of AFP® rotary actuator Extended life when use with AFP® actuator	YES YES	PARTIALLY NO

• : Standard      A : Available      N/A : Not Available



Analytical Flow Products

# SHORT TUTORIAL AND TECHNICAL NOTE ON THE RV FAMILY

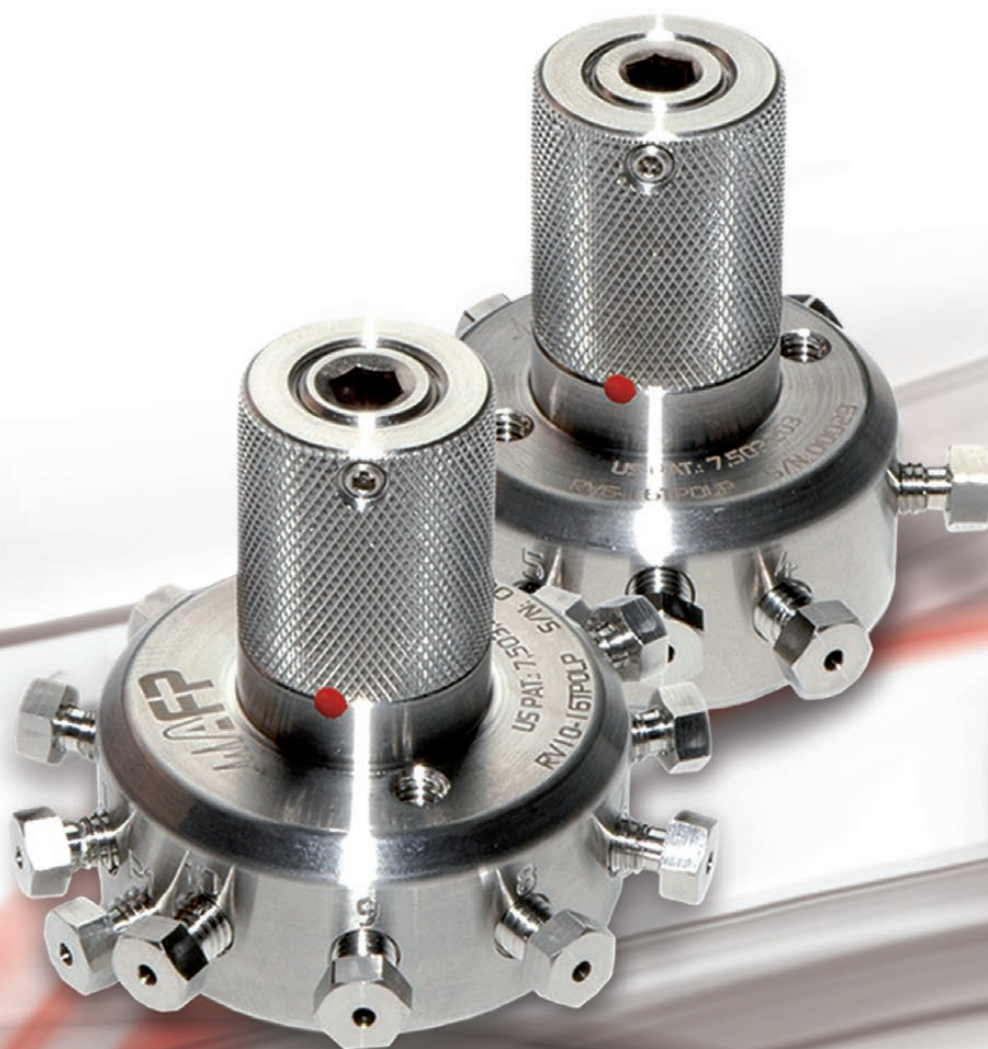



# HISTORY



**Spool base valve**  
1960

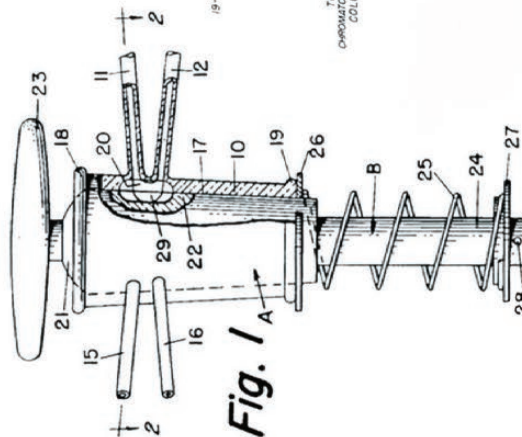

US PAT. # 3,116,642  
**Conical rotary valve**  
1961

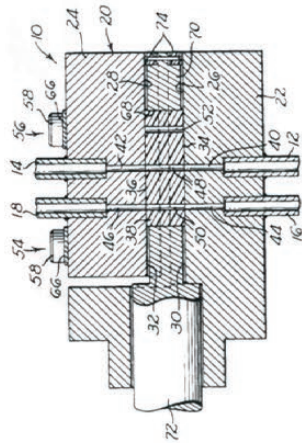

US PAT. # 3,160,015  
**Linear sliding valve**  
1961

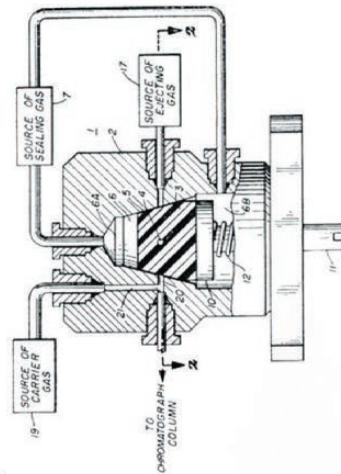

US PAT. # 3,475,950  
**Conical rotary valve**  
1966

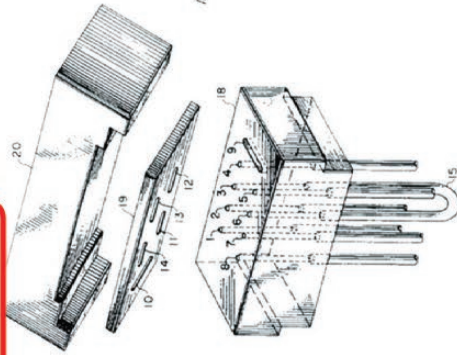

US PAT. # 3,800,602  
**Linear sliding valve**  
1970

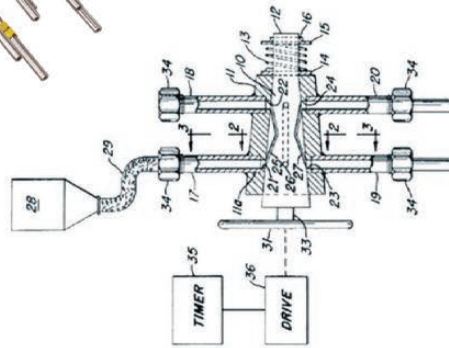

US PAT. # 2,830,738  
**Conical rotary valve**  
1956

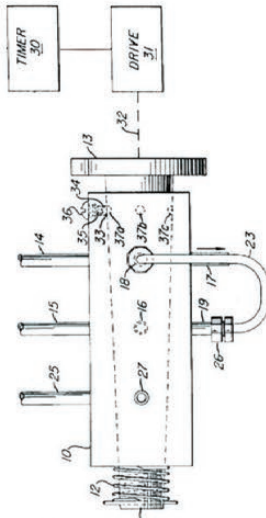

US PAT. # 2,972,888  
**Conical rotary valve**  
1957



**Flat rotary valve**



**Purge rotary valve**  
with O-ring  
2012



**Conical rotary valve**  
in the 60's

- Carles
- Chandler engineering
- Valco

# RV-SERIES\*

## General purpose

### mini-generic :

- ✓ Eliminate side loading
- ✓ Eliminate rotor/port misalignment
- ✓ Reduce Friction
- ✓ Fine tuning of preload force

### Purge valve :

- ✓ OLP-SERIES (I/O leak protection)
- ✓ CLP-SERIES (D & S)  
(Extra cross port leak protection)
- ✓ S-SERIES  
(Sample stream selections valve)



\* U.S.pat# 7,503,203 / Chinese pat# CN101044346 / other patents pending.

# COMMERCIAL VALVE AND ACTUATION MECHANISM

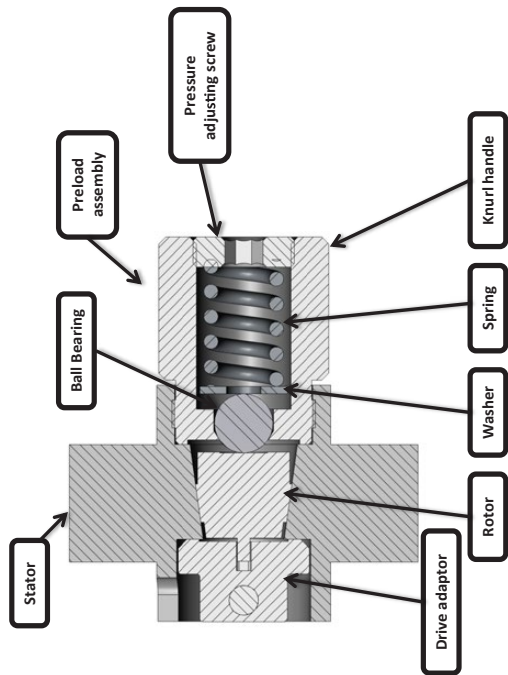

**Standard version**

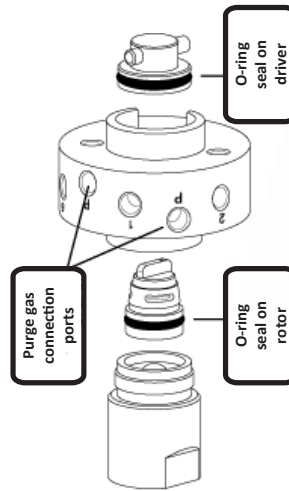

**Purged with o-ring version**

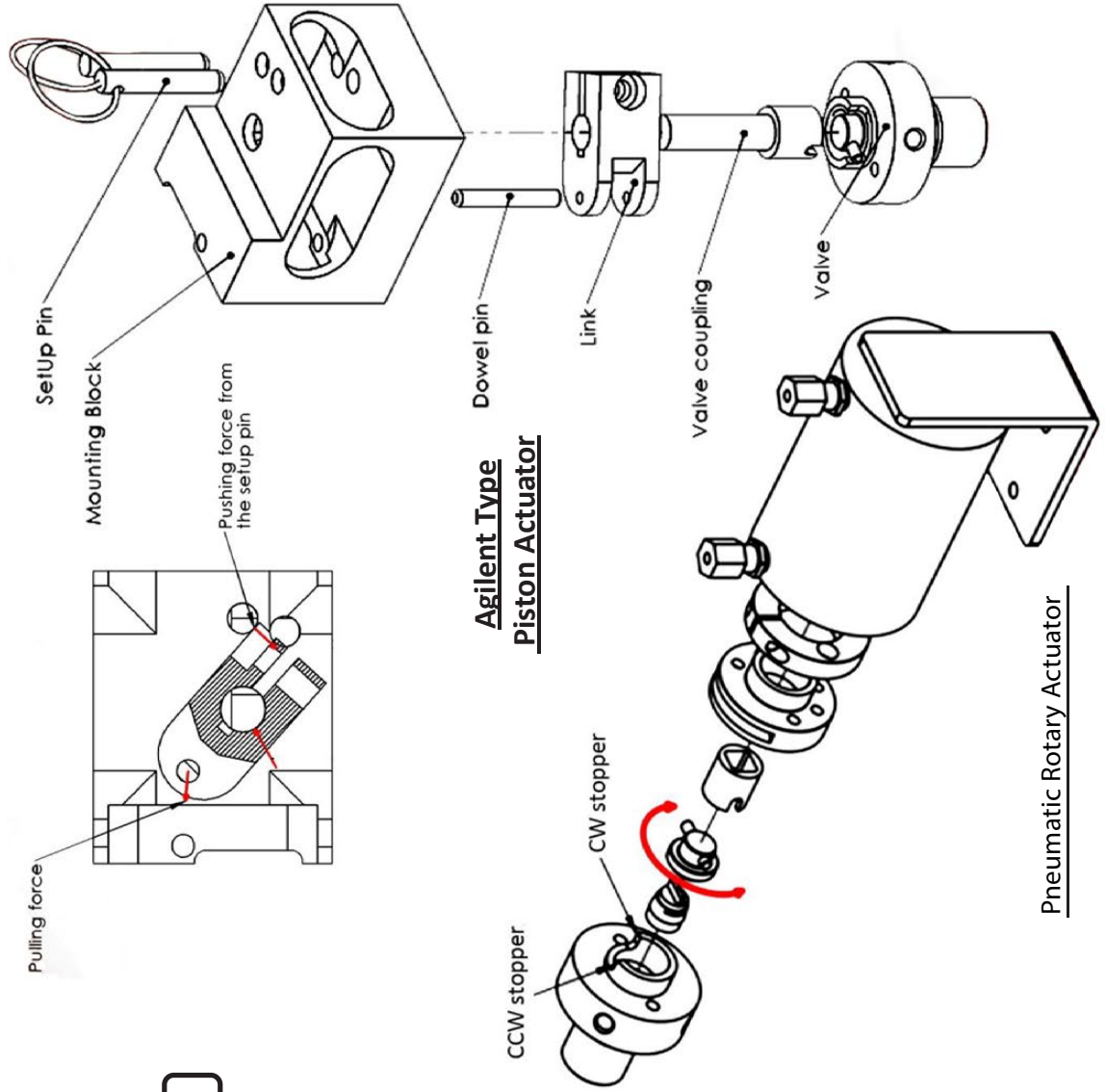

**Agilent Type Piston Actuator**

**Pneumatic Rotary Actuator**

# SIDE LOADING PROBLEM

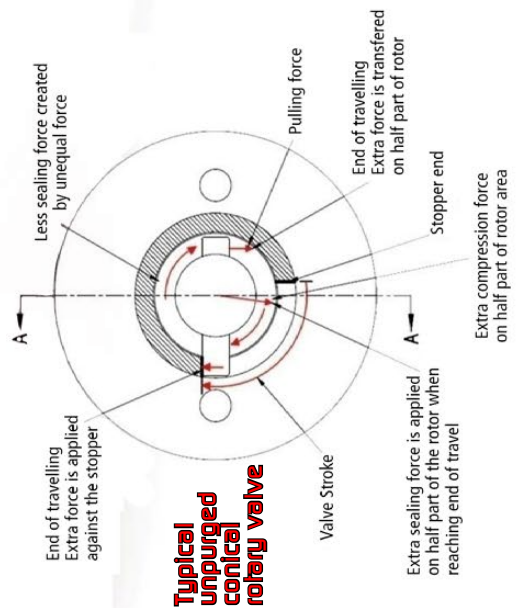

**Typical unpurged conical rotary valve**

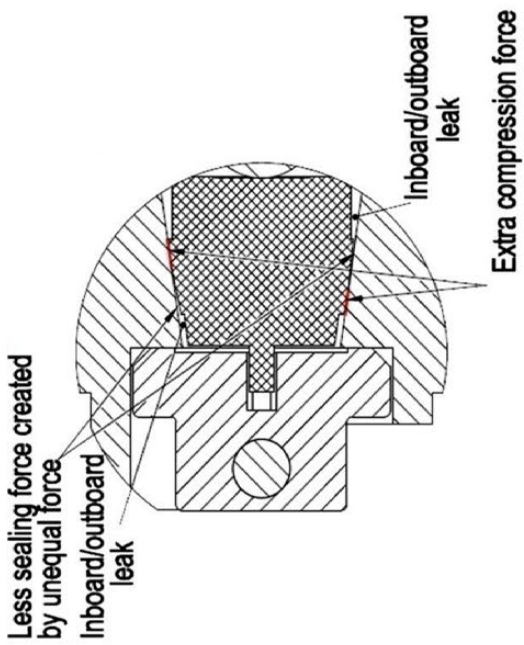

**Unwanted force transfer to the rotor**

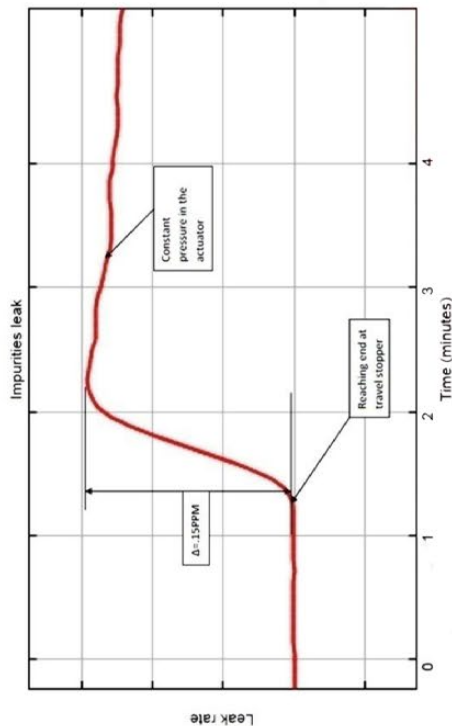
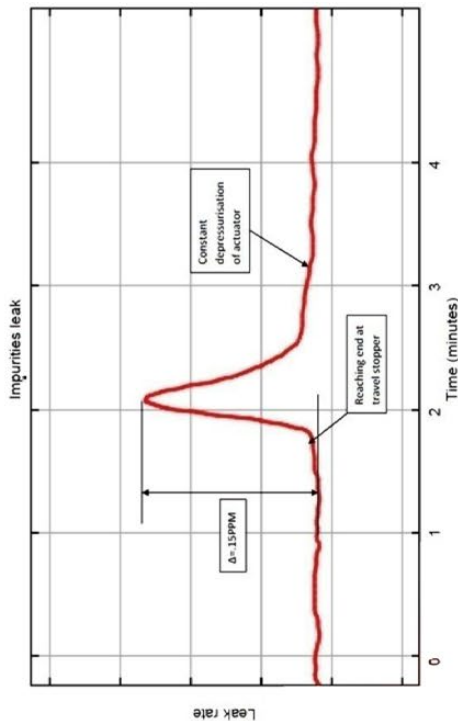

**Previous stator related problems due to the unwanted force transmitted to the rotor's sealing material**

# AFP ROTARY VALVE CONFIGURATION, NEW SOLUTION

- ✓ Eliminate side loading
- ✓ Eliminate rotor/port misalignment
- ✓ Reduce Friction
- ✓ Fine tuning of preload force

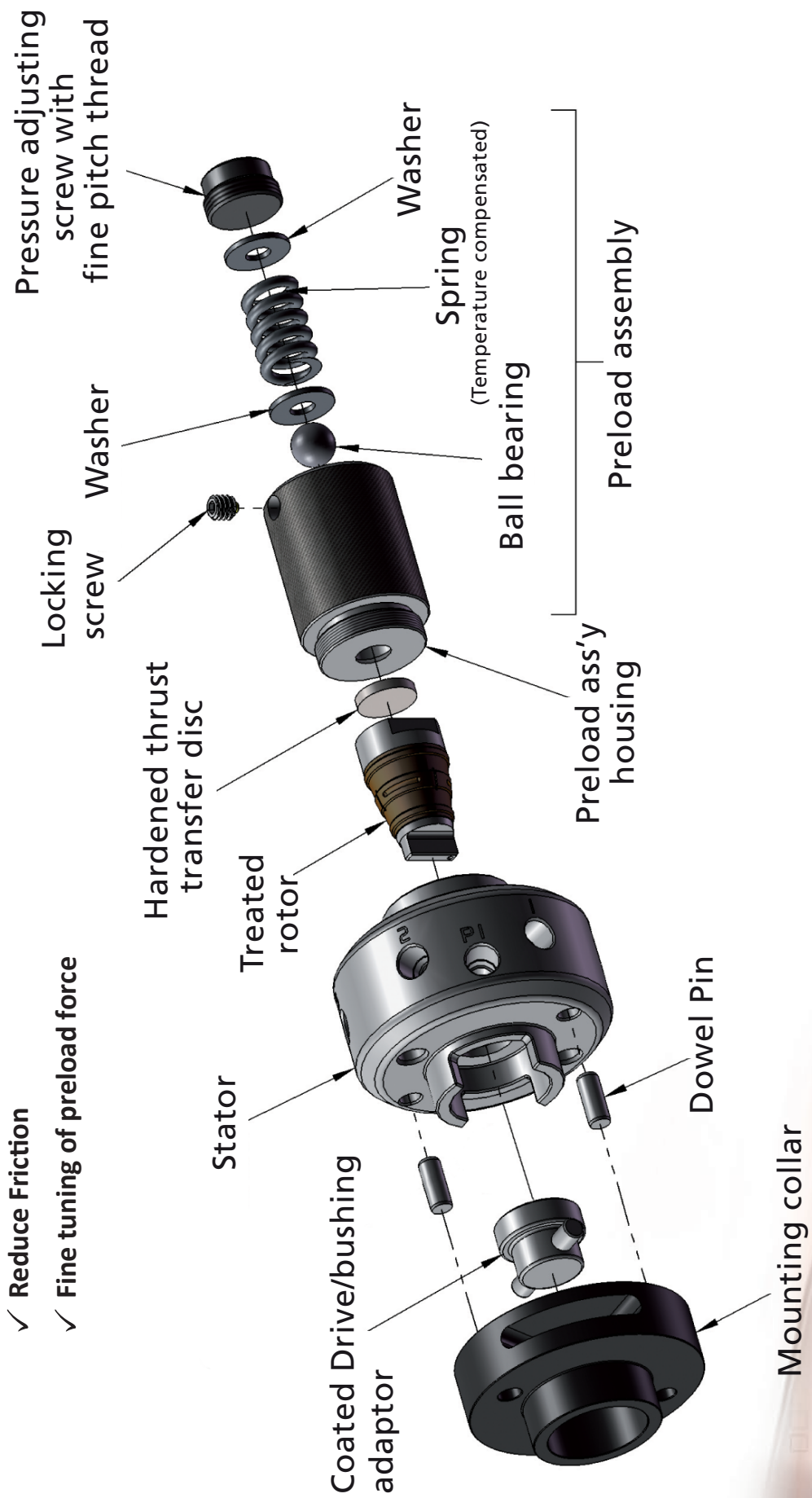

**RESULTS**

**AFP NEW Design**

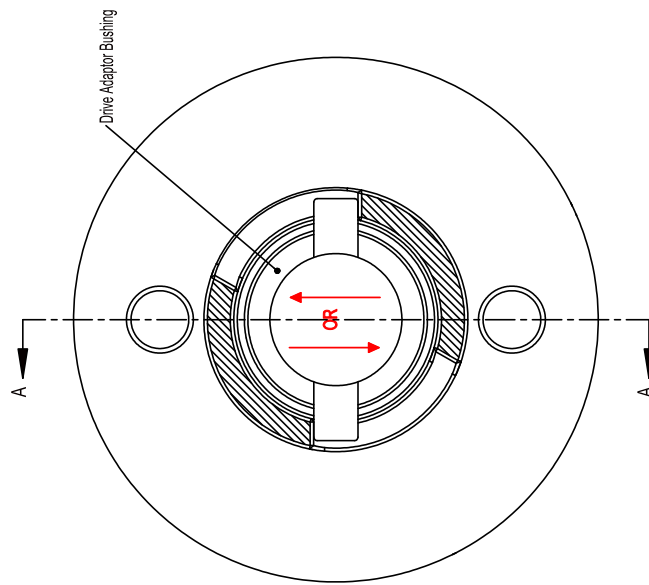

Making sure that no radial force is transferred to the rotor

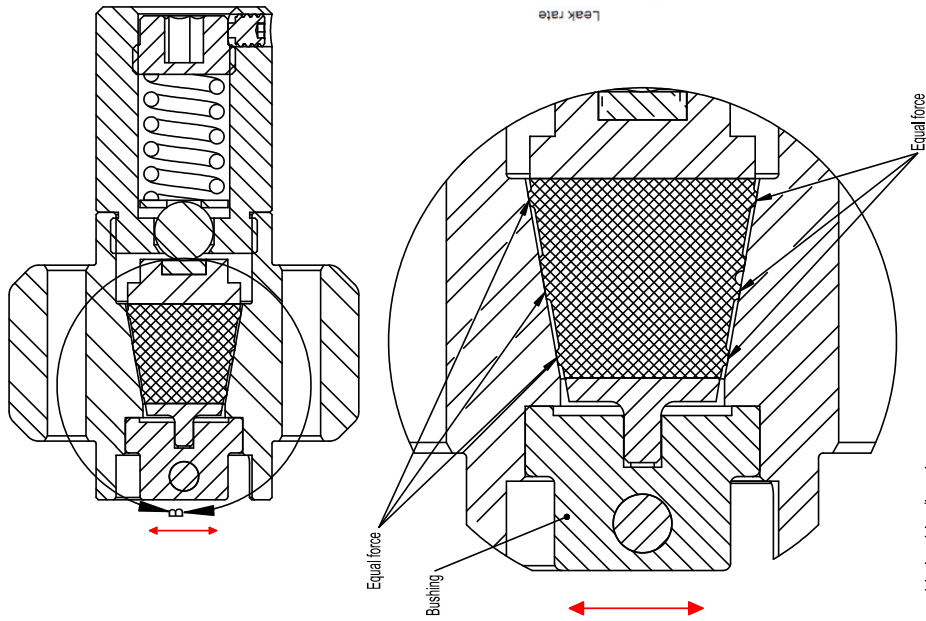

Improved version, addition of a guide bushing/bearing

**Making sure that no radial force is transferred to the rotor**

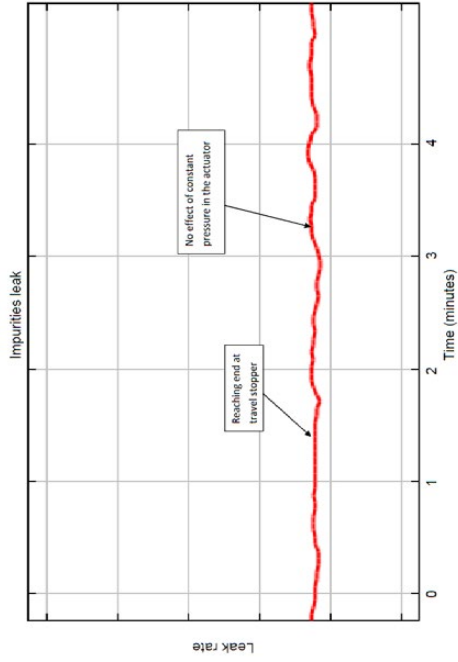

**Valve mount on PNC type pneumatic actuator**

# INNOVATIVE PURGE ROTOR CONFIGURATION

## G-SERIES (Generic)

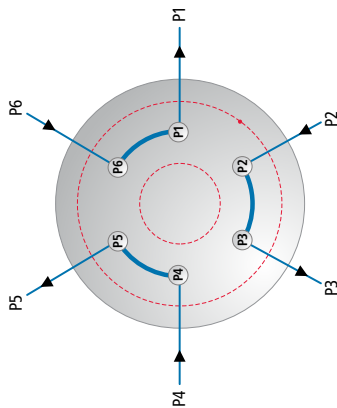

- Improved torque transfer
- Treated rotor surface
- Direct drop-in replacement of commercial GC valves

## OLP-SERIES (Outboard Leak Purge)

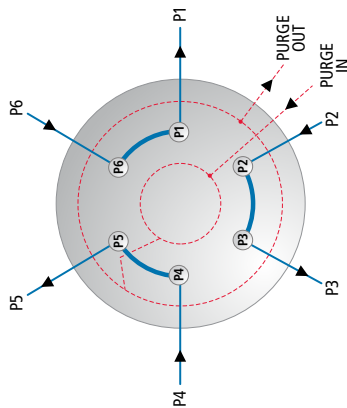
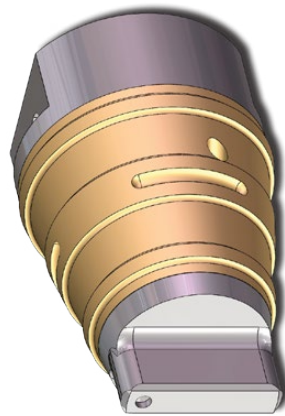

- Sealing/Purging grooves, prevent Inboard /Outboard contamination

# INNOVATIVE PURGE ROTOR CONFIGURATION

## (Cross Port Leak Purge)

**CLP-D**  
(Dynamic)

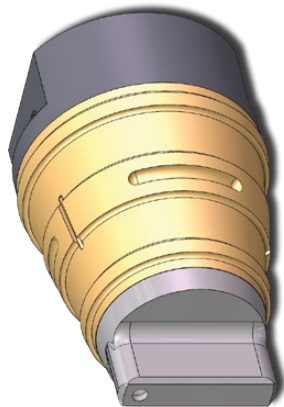

**Continuous purge flow**

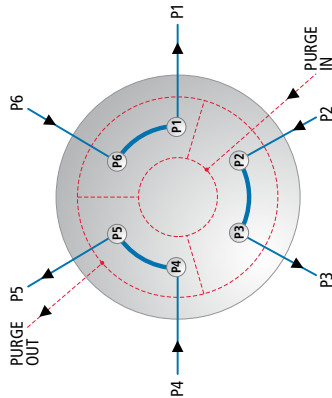

➤ Sealing / Purging grooves added between cross port grooves, prevents cross port leak

➤ Longer lifetime

**CLP-S**  
(Static)

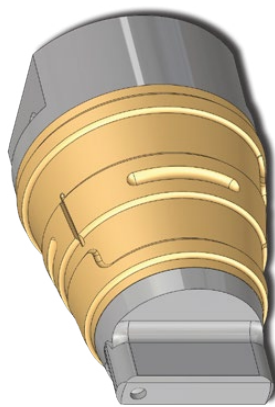

**Purge flow port stop and isolated upon rotation**

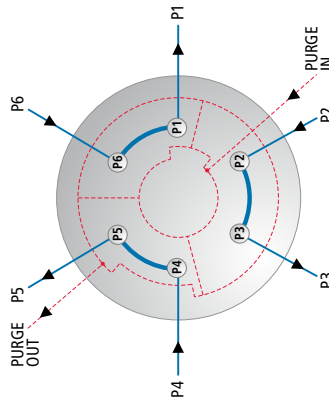

➤ Static configuration prevents sending the sample fluid and carrier to the purge vent. Good when system pressure is high.



# INNOVATIVE PURGE ROTOR CONFIGURATION

## Purged sample stream selection valve

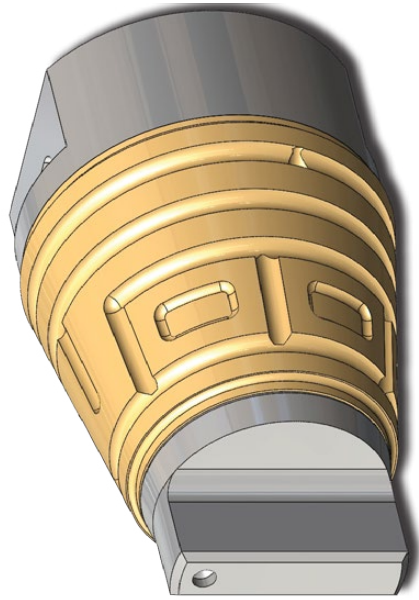

**S-SERIES  
(Selection)**

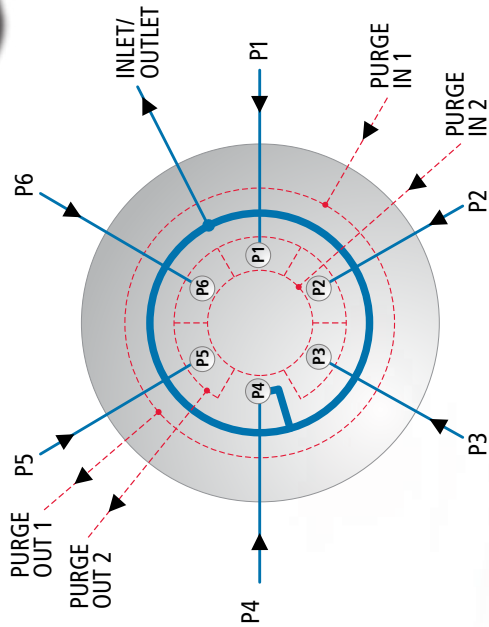

➤ Sealing / Purging grooves between sample inlet ports, prevents cross port, Inboard / Outboard contamination.

# INNOVATIVE PURGE ROTOR CONFIGURATION

## ISL-SERIES (Internal Sampling Loop)

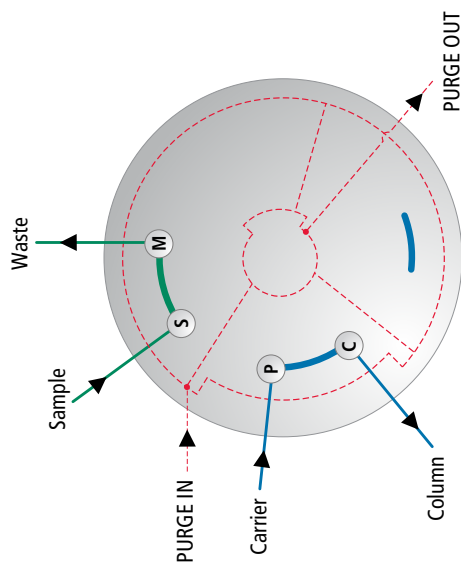

### INJECT Mode:

Sample is injected into the column

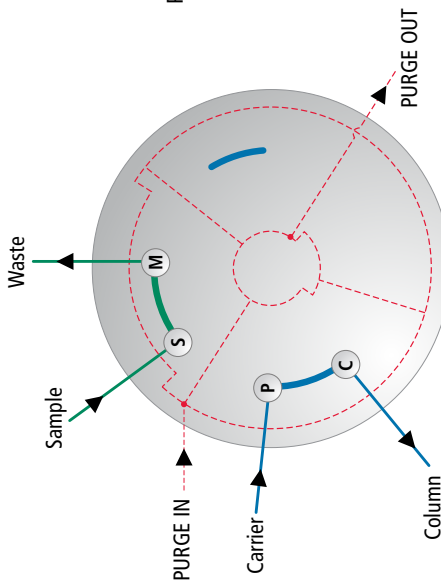

### LOAD Mode:

Sample is loaded into the sampling loop

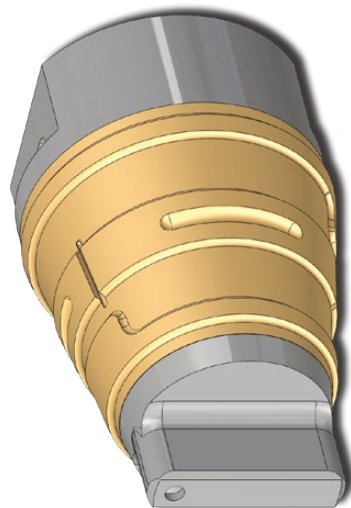

### Rotor:

CLP-S Rotor with internal sampling loop

Available Internal Sampling Loop volume: **0.05µl, 0.2µl, 0.5µl, 1.0µl, 2.0µl**

**BENEFIT OF THE PURGE IN AFP CLP-TYPE ROTARY VALVE**

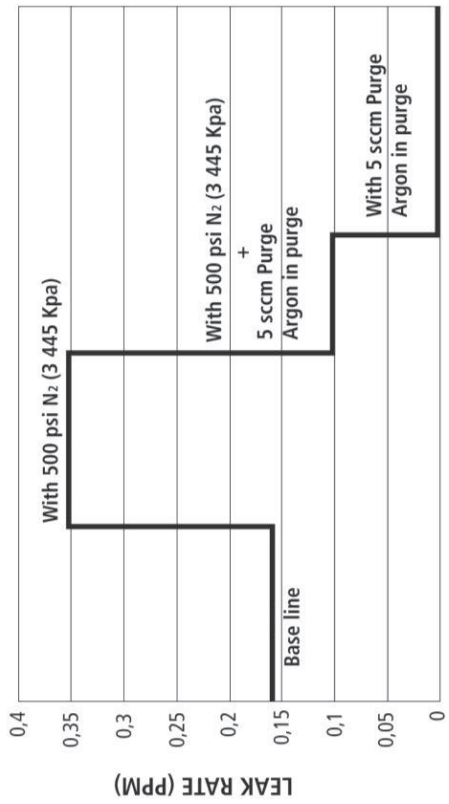

Leak flow from process to purge at 125 cc/min.

**PERFORMANCE COMPARISON: COMMERCIAL ANS OUR'S**

Test done by  
third party lab

cmc Instruments GmbH

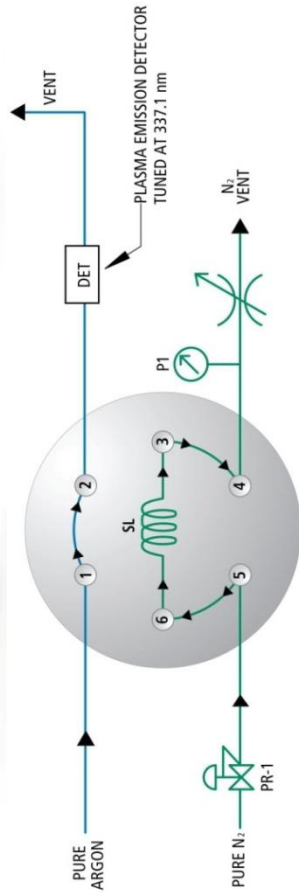

**Test pressure P1 at 400 psig (2 757 Kpa)**  
Standard configuration

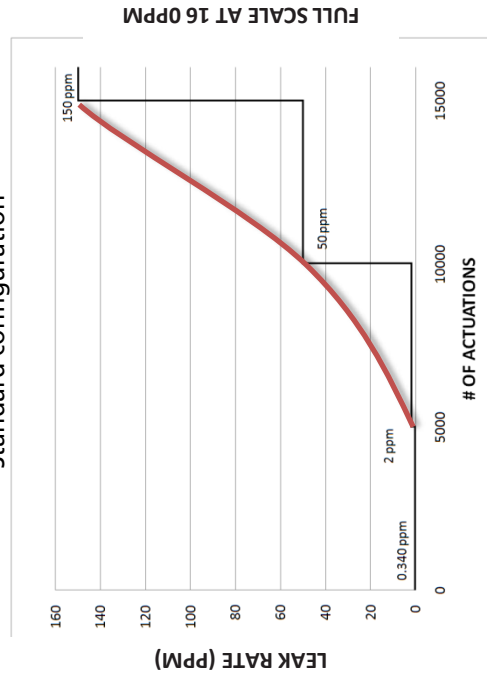

**Averaged test on 10 units**

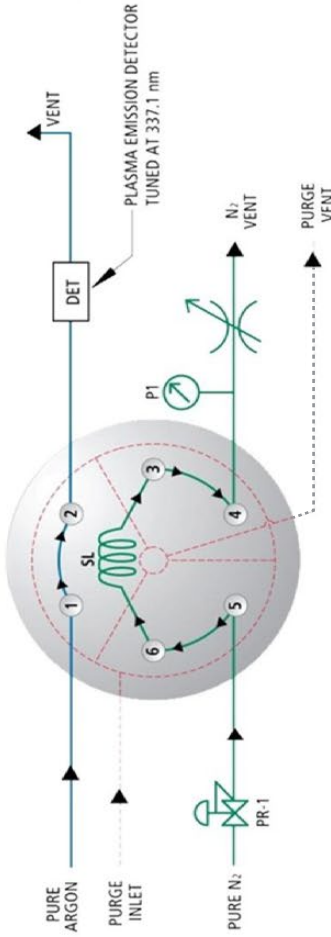

**Test pressure P1 at 500 psig (3345 Kpa)**  
AFP model **CLP**



# AFP ACTUATORS

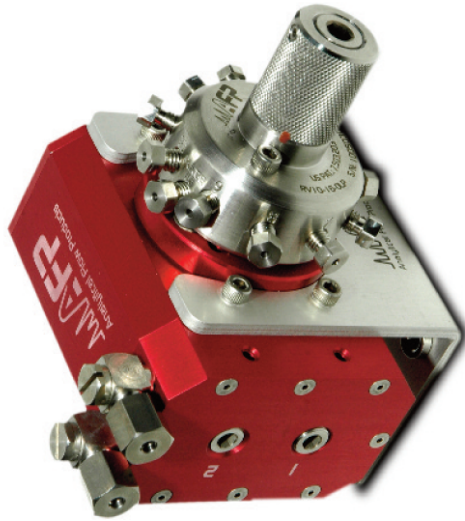

Pneumatic Actuator  
PNC-SERIES



Manual Actuator



Mini Electrical Actuator  
(MEA-SERIES)

- Only power supply required
- Interface: dry contact / serial interface
- User programmable
- Stroke eliminating by firmware
- Right angle available



Standoff  
2", 4" and 6"







Analytical Flow Products

233, Jalbert St. W., Thetford Mines, QC, Canada G6G 7W1  
Phone: 418.338.0004 Fax: 418.338.2500  
Email: info@afproducts.ca

[www.afproducts.ca](http://www.afproducts.ca)